

Deret Fourier

Febrizal, MT

Fungsi Periodik

- Fungsi $f(x)$ dikatakan periodik apabila nilai fungsi tersebut berulang pada interval reguler .
- Interval reguler antara pengulangan adalah periode dari osilasi.

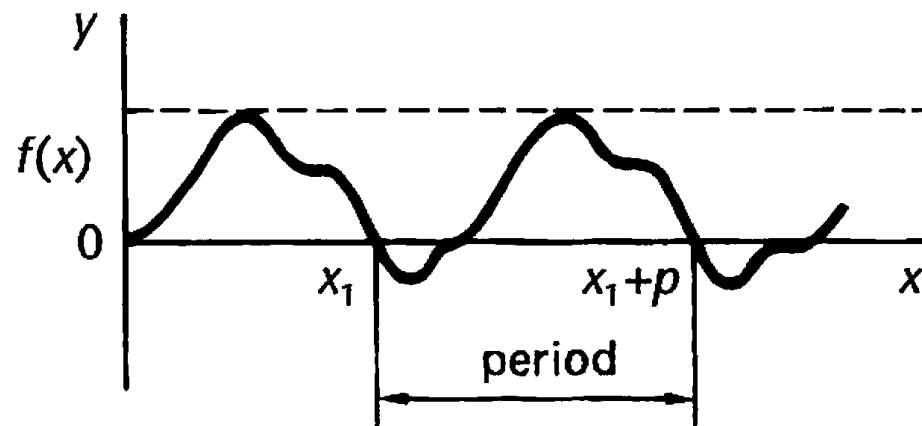

Grafik $y = A \sin nx$

- (a) $y = \sin x$
 - Contoh nyata dari fungsi periodik adalah $y = \sin x$.
 - Periodenya 360° atau 2π dengan amplituda maksimum = 1

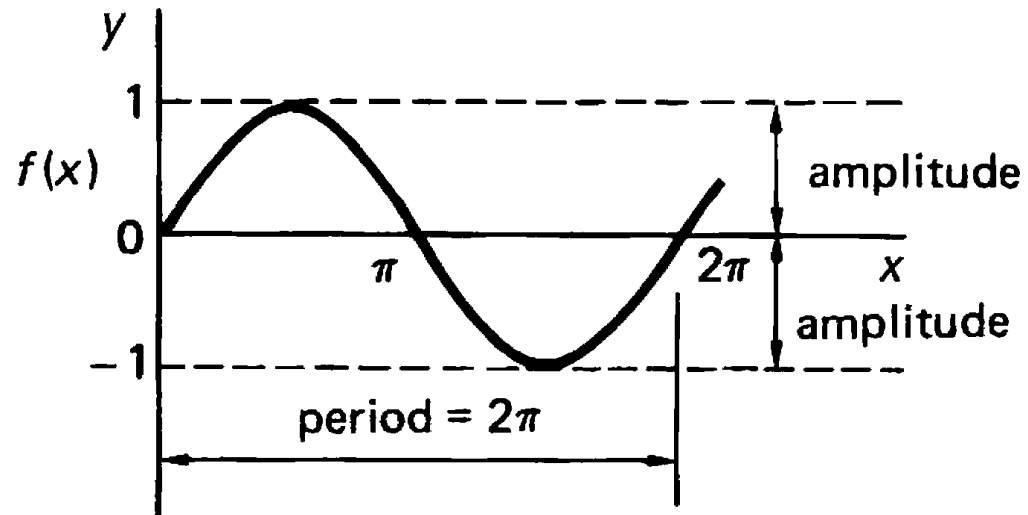

- (b) $y = 5 \sin 2x$
 - Amplitudanya adalah 5.
 - Periodanya adalah 180° dan ada 2 gelombang penuh dalam 360° .

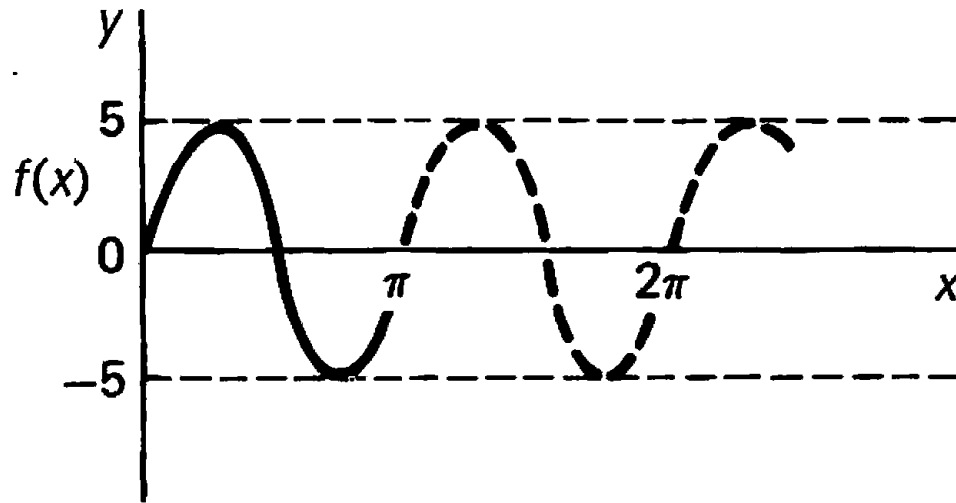

- (c) $y = A \sin nx$
 - Dari dua contoh sebelumnya, maka bisa disimpulkan bahwa fungsi $y = A \sin nx$ mempunyai amplituda A dan periode = $360^\circ/n$ dan ada n buah gelombang penuh dalam 360° .

Fungsi Periode Bukan Sinus

- Contoh

- Pada kasus berikut, sumbu x memuat skala dari t dalam mili detik.

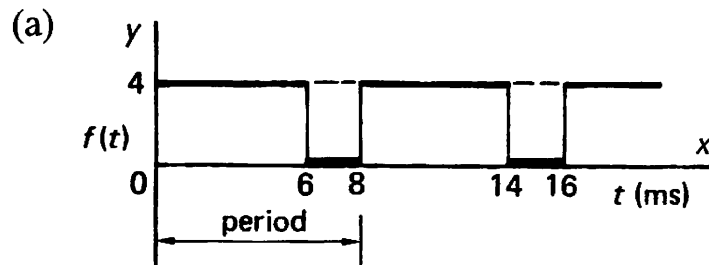

period = 8 ms

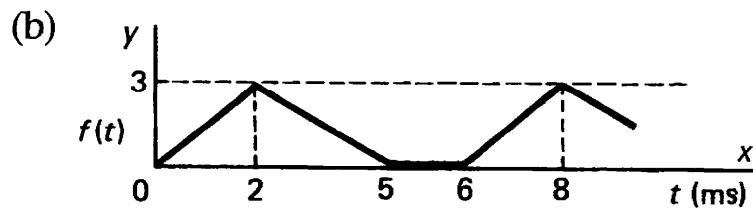

period = 6 ms...

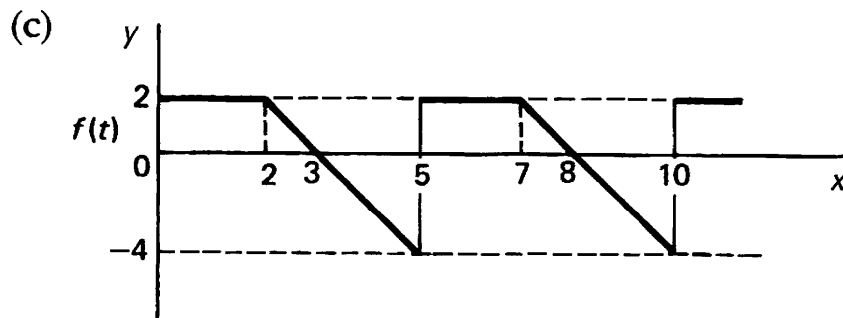

period = 5 ms..

Deskripsi Analitik Fungsi Periodik

- Contoh 1

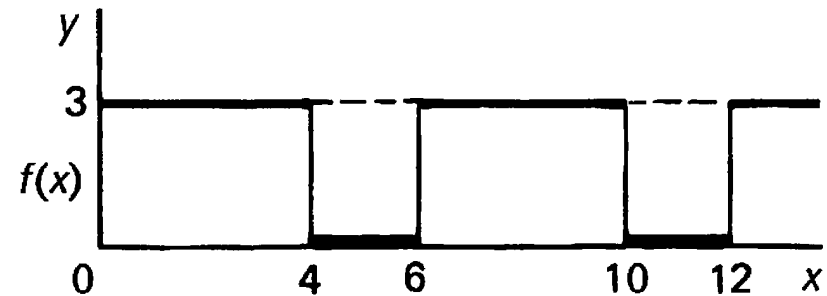

- Antara $x = 0$ dan $x = 4$, $y = 3$, berarti $f(x) = 3$ $0 < x < 4$
- Antara $x = 4$ dan $x = 6$, $y = 0$, berarti $f(x) = 0$ $4 < x < 6$
- Jadi kita bisa mendefinisikan fungsi sebagai

$$f(x) = \begin{cases} 3 & 0 < x < 4 \\ 0 & 4 < x < 6 \end{cases}$$

$$f(x + 6) = f(x)$$

- Baris terakhir menandakan bahwa fungsi adalah periodik dengan periode 6 satuan.

Example 3

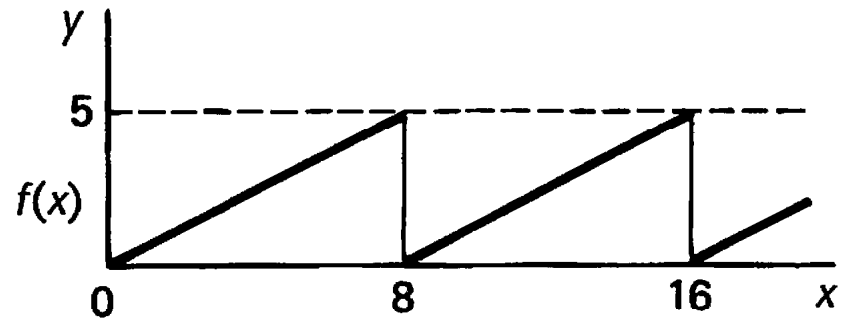

$$f(x) = \frac{5x}{8} \quad 0 < x < 8$$

$$f(x+8) = f(x)$$

- Latihan

- Nyatakan fungsi periodik berikut secara analitik

- (a)

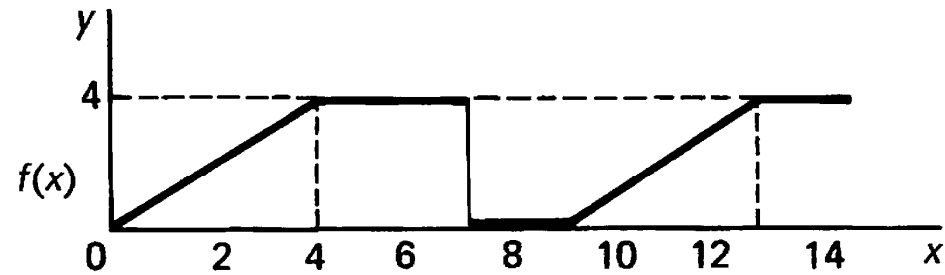

- (b)

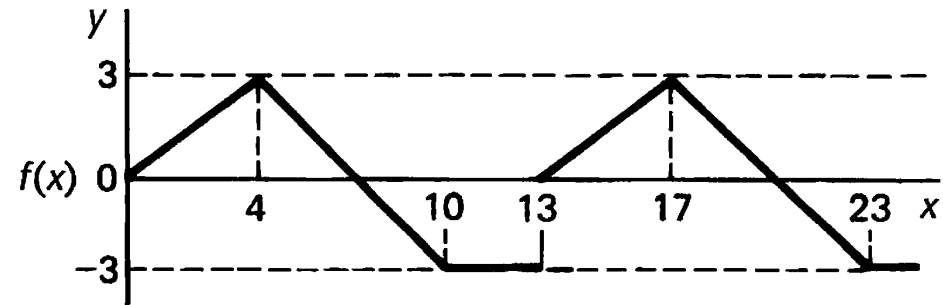

- (c)

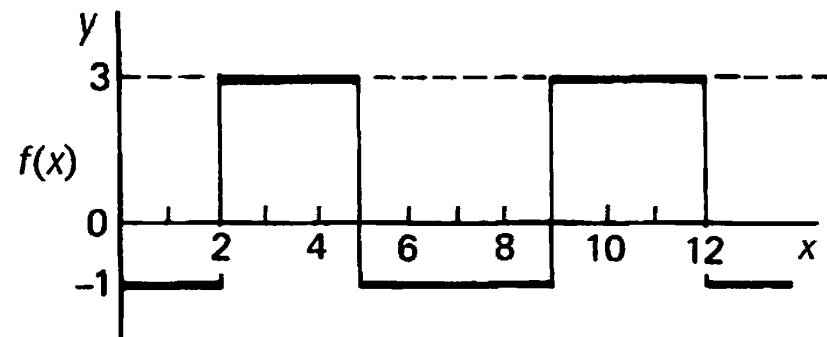

- Jawaban

- (a)
$$f(x) = \begin{cases} x & 0 < x < 4 \\ 4 & 4 < x < 7 \\ 0 & 7 < x < 9 \end{cases}$$

$$f(x + 9) = f(x).$$

- (b)
$$f(x) = \begin{cases} \frac{3x}{4} & 0 < x < 4 \\ 7 - x & 4 < x < 10 \\ -3 & 10 < x < 13 \end{cases}$$

$$f(x + 13) = f(x).$$

- (c)
$$f(x) = \begin{cases} -1 & 0 < x < 2 \\ 3 & 2 < x < 5 \\ -1 & 5 < x < 7 \end{cases}$$

$$f(x + 7) = f(x).$$

Integral Fungsi Periodik

$$\mathbf{1} \quad \int_{-\pi}^{\pi} dx = [x]_{-\pi}^{\pi} = 2\pi$$

$$\mathbf{2} \quad \int_{-\pi}^{\pi} \cos nx \, dx = 0$$

$$\mathbf{3} \quad \int_{-\pi}^{\pi} \sin nx \, dx = 0$$

$$\mathbf{4} \quad \int_{-\pi}^{\pi} \cos mx \cos nx \, dx = \pi \delta_{mn} \quad \text{where } \delta_{mn} = \begin{cases} 1 & \text{if } m = n \\ 0 & \text{if } m \neq n \end{cases}$$

(δ_{mn} is called the Kronecker delta)

$$\mathbf{5} \quad \int_{-\pi}^{\pi} \sin mx \sin nx \, dx = \pi \delta_{mn}$$

$$\mathbf{6} \quad \int_{-\pi}^{\pi} \cos mx \sin nx \, dx = 0$$

Deret Fourier

- Jika suatu fungsi $f(x)$ mempunyai periode 2π , maka deret fourier fungsi tersebut adalah:

$$f(x) = \frac{a_0}{2} + \sum_{n=1}^{\infty} (a_n \cos nx + b_n \sin nx)$$

- a_n dan b_n adalah konstanta yang disebut koefisien fourier.
- Dimana $a_0 = \frac{1}{2\pi} \int_{-\pi}^{\pi} f(x) dx$, $a_n = \frac{1}{\pi} \int_{-\pi}^{\pi} f(x) \cos nx dx$ ($n \neq 0$), dan

$$b_n = \frac{1}{\pi} \int_{-\pi}^{\pi} f(x) \sin nx dx.$$

- Contoh 1

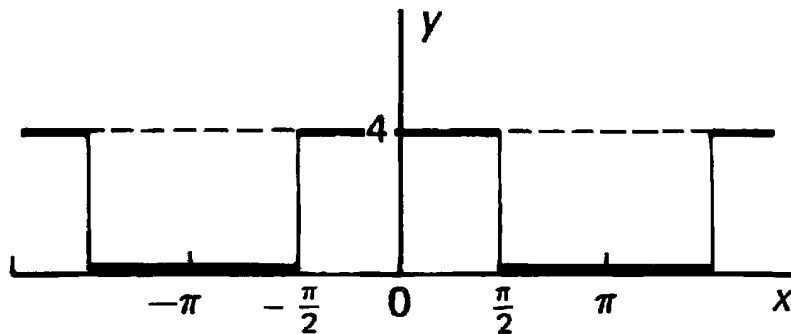

Find the Fourier series for the function shown.

Consider one cycle between $x = -\pi$ and $x = \pi$.

The function can be defined by $f(x) = \begin{cases} 0 & -\pi < x < -\frac{\pi}{2} \\ 4 & -\frac{\pi}{2} < x < \frac{\pi}{2} \\ 0 & \frac{\pi}{2} < x < \pi \end{cases}$

$$f(x + 2\pi) = f(x).$$

(a) As before $f(x) = \frac{1}{2}a_0 + \sum_{n=1}^{\infty} \{a_n \cos nx + b_n \sin nx\}$

$$\begin{aligned}
 a_0 &= \frac{1}{\pi} \left\{ \int_{-\pi}^{-\pi/2} 0 \, dx + \int_{-\pi/2}^{\pi/2} 4 \, dx + \int_{\pi/2}^{\pi} 0 \, dx \right\} \\
 &= \frac{1}{\pi} \left[4x \right]_{-\pi/2}^{\pi/2} \qquad \therefore a_0 = 4
 \end{aligned}$$

(b) To find a_n

$$\begin{aligned}
 a_n &= \frac{1}{\pi} \int_{-\pi}^{\pi} f(x) \cos nx \, dx \\
 \therefore a_n &= \frac{1}{\pi} \left\{ \int_{-\pi}^{-\pi/2} (0) \cos nx \, dx + \int_{-\pi/2}^{\pi/2} 4 \cos nx \, dx + \int_{\pi/2}^{\pi} (0) \cos nx \, dx \right\}
 \end{aligned}$$

$$a_n = \frac{8}{\pi n} \sin \frac{n\pi}{2}$$

If n is even

$$a_n = 0$$

If $n = 1, 5, 9, \dots$

$$a_n = \frac{8}{n\pi}$$

If $n = 3, 7, 11, \dots$

$$a_n = -\frac{8}{n\pi}$$

(c) To find b_n

$$b_n = \frac{1}{\pi} \int_{-\pi}^{\pi} f(x) \sin nx \, dx = \dots\dots\dots$$

$$b_n = \frac{1}{\pi} \left\{ \int_{-\pi}^{-\pi/2} (0) \sin nx \, dx + \int_{-\pi/2}^{\pi/2} 4 \sin nx \, dx + \int_{\pi/2}^{\pi} (0) \sin nx \, dx \right\}$$

$$= \frac{4}{\pi} \int_{-\pi/2}^{\pi/2} \sin nx \, dx = \frac{4}{\pi} \left[\frac{-\cos nx}{n} \right]_{-\pi/2}^{\pi/2}$$

$$= -\frac{4}{n\pi} \left\{ \cos \frac{n\pi}{2} - \cos \left(\frac{-n\pi}{2} \right) \right\} = 0 \qquad \therefore b_n = 0$$

So with $a_0 = 4$; a_n as stated above; $b_n = 0$; the Fourier series is

$$f(x) = 2 + \frac{8}{\pi} \left\{ \cos x - \frac{1}{3} \cos 3x + \frac{1}{5} \cos 5x - \frac{1}{7} \cos 7x + \dots \right\}$$

Example 2

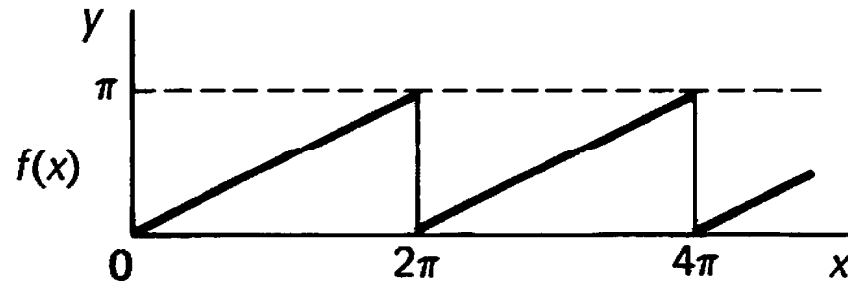

Determine the Fourier series to represent the periodic function shown.

It is more convenient here to take the limits as 0 to 2π .

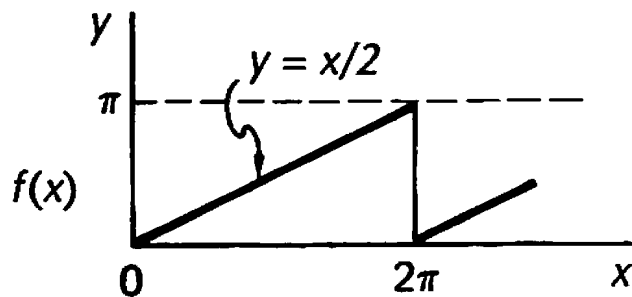

The function can be defined as

$$f(x) = \frac{x}{2} \quad 0 < x < 2\pi$$

$$f(x + 2\pi) = f(x) \quad \text{i.e. period} = 2\pi.$$

Now to find the coefficients.

$$\begin{aligned} \text{(a) } a_0 &= \frac{1}{\pi} \int_0^{2\pi} f(x) \, dx = \frac{1}{\pi} \int_0^{2\pi} \left(\frac{x}{2}\right) \, dx = \frac{1}{4\pi} \left[x^2 \right]_0^{2\pi} \\ &= \pi \qquad \qquad \qquad \therefore a_0 = \pi \end{aligned}$$

$$\begin{aligned} \text{(b) } a_n &= \frac{1}{\pi} \int_0^{2\pi} f(x) \cos nx \, dx = \frac{1}{\pi} \int_0^{2\pi} \left(\frac{x}{2}\right) \cos nx \, dx \\ &= \frac{1}{2\pi} \int_0^{2\pi} x \cos nx \, dx \\ a_n &= \frac{1}{2\pi} \int_0^{2\pi} x \cos nx \, dx = \frac{1}{2\pi} \left\{ \left[\frac{x \sin nx}{n} \right]_0^{2\pi} - \frac{1}{n} \int_0^{2\pi} \sin nx \, dx \right\} \\ &= \frac{1}{2\pi} \left\{ (0 - 0) - \frac{1}{n} (0) \right\} = 0 \qquad \qquad \qquad \therefore a_n = 0 \end{aligned}$$

$$(c) \quad b_n = \frac{1}{\pi} \int_0^{2\pi} f(x) \sin nx \, dx = \dots\dots\dots$$

$$b_n = -\frac{1}{n}$$

$$f(x) = \frac{1}{2}a_0 + \sum_{n=1}^{\infty} \{a_n \cos nx + b_n \sin nx\}$$

$$f(x) = \frac{\pi}{2} + \sum_{n=1}^{\infty} \{b_n \sin nx\} \quad \text{because } a_n = 0$$

$$= \frac{\pi}{2} + \left\{ -\frac{1}{1} \sin x - \frac{1}{2} \sin 2x - \frac{1}{3} \sin 3x - \dots \right\}$$

$$\therefore f(x) = \frac{\pi}{2} - \left\{ \sin x + \frac{1}{2} \sin 2x + \frac{1}{3} \sin 3x + \dots \right\}$$

Example 3

Find the Fourier series for the function defined by

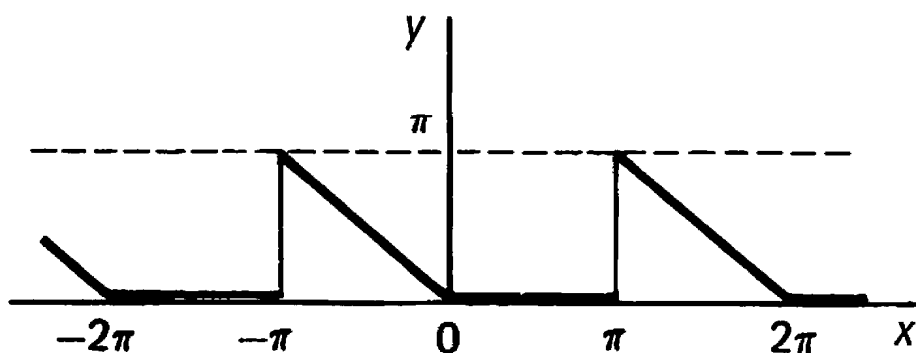

$$f(x) = -x \quad -\pi < x < 0$$

$$f(x) = 0 \quad 0 < x < \pi$$

$$f(x + 2\pi) = f(x).$$

The general expressions for a_0 , a_n , b_n are

$$a_0 = \dots\dots\dots$$

$$a_n = \dots\dots\dots$$

$$b_n = \dots\dots\dots$$

$$a_0 = \frac{1}{\pi} \int_{-\pi}^{\pi} f(x) dx = \frac{1}{\pi} \int_{-\pi}^0 (-x) dx = \frac{1}{\pi} \left[-\frac{x^2}{2} \right]_{-\pi}^0 = \frac{\pi}{2}$$

$$\begin{aligned} a_n &= \frac{1}{\pi} \int_{-\pi}^{\pi} f(x) \cos nx dx = \frac{1}{\pi} \int_{-\pi}^0 (-x) \cos nx dx \\ &= -\frac{1}{\pi} \int_{-\pi}^0 x \cos nx dx \\ &= -\frac{1}{\pi} \left\{ \left[x \frac{\sin nx}{n} \right]_{-\pi}^0 - \frac{1}{n} \int_{-\pi}^0 \sin nx dx \right\} \\ &= -\frac{1}{\pi} \left\{ (0 - 0) - \frac{1}{n} \left[\frac{-\cos nx}{n} \right]_{-\pi}^0 \right\} = -\frac{1}{\pi n^2} \{1 - \cos n\pi\} \end{aligned}$$

But $\cos n\pi = 1$ (n even) or -1 (n odd)

$$\therefore a_n = -\frac{2}{\pi n^2} \quad (n \text{ odd}) \quad \text{or} \quad 0 \quad (n \text{ even})$$

$$\begin{aligned}
b_n &= \frac{1}{\pi} \int_{-\pi}^{\pi} f(x) \sin nx \, dx = \frac{1}{\pi} \int_{-\pi}^0 (-x) \sin nx \, dx \\
&= -\frac{1}{\pi} \int_{-\pi}^0 x \sin nx \, dx \\
&= -\frac{1}{\pi} \left\{ \left[x \left(\frac{-\cos nx}{n} \right) \right]_{-\pi}^0 + \frac{1}{n} \int_{-\pi}^0 \cos nx \, dx \right\} \\
&= -\frac{1}{\pi} \left\{ \frac{\pi \cos n\pi}{n} + \frac{1}{n} \left[\frac{\sin nx}{n} \right]_{-\pi}^0 \right\} = -\frac{\cos n\pi}{n}
\end{aligned}$$

$$\therefore b_n = -\frac{1}{n} \quad (n \text{ even}); \quad \frac{1}{n} \quad (n \text{ odd})$$

$$\begin{aligned}
f(x) &= \frac{\pi}{4} - \frac{2}{\pi} \left(\cos x + \frac{1}{9} \cos 3x + \frac{1}{25} \cos 5x + \dots \right) \\
&\quad + \left(\sin x - \frac{1}{2} \sin 2x + \frac{1}{3} \sin 3x - \frac{1}{4} \sin 4x + \dots \right)
\end{aligned}$$

Deret Fourier Fungsi Dengan Perioda T

- Jika suatu fungsi mempunyai perioda T, maka deret fourier fungsi tersebut adalah:

$$f(t) = \frac{1}{2}a_0 + \sum_{n=1}^{\infty} \{a_n \cos n\omega t + b_n \sin n\omega t\}$$

$$a_0 = \frac{2}{T} \int_0^T f(t) dt = \frac{\omega}{\pi} \int_0^{2\pi/\omega} f(t) dt$$

$$a_n = \frac{2}{T} \int_0^T f(t) \cos n\omega t dt = \frac{\omega}{\pi} \int_0^{2\pi/\omega} f(t) \cos n\omega t dt$$

$$b_n = \frac{2}{T} \int_0^T f(t) \sin n\omega t dt = \frac{\omega}{\pi} \int_0^{2\pi/\omega} f(t) \sin n\omega t dt$$

$$\text{where } \omega = \frac{2\pi}{T} \text{ i.e. } T = \frac{2\pi}{\omega}.$$

- Contoh 1

- Tentukanlah deret fourier dari fungsi berikut:

$$f(t) = \begin{cases} 2(1+t) & -1 < t < 0 \\ 0 & 0 < t < 1 \end{cases}$$

$$f(t+2) = f(t)$$

- Penyelesaian

- Pertama kita gambarkan bentuk gelombang persamaan:

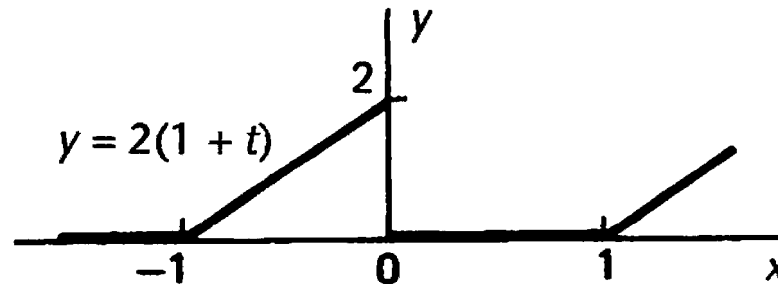

- Kita peroleh:

$$\begin{aligned} f(t) &= \frac{a_0}{2} + \sum_{n=1}^{\infty} \left\{ a_n \cos \frac{2n\pi t}{T} + b_n \sin \frac{2n\pi t}{T} \right\} \\ &= \frac{a_0}{2} + \sum_{n=1}^{\infty} \{ a_n \cos n\pi t + b_n \sin n\pi t \} \quad \text{because } T = 2 \end{aligned}$$

– Maka;

$$\begin{aligned} a_0 &= \frac{2}{T} \int_{-T/2}^{T/2} f(t) dt = \int_{-1}^1 f(t) dt = \int_{-1}^0 2(1+t) dt + \int_0^1 (0) dt \\ &= \left[2t + t^2 \right]_{-1}^0 = 1 \end{aligned}$$

– dan

$$\begin{aligned} a_n &= \frac{2}{T} \int_{-T/2}^{T/2} f(t) \cos n\pi t dt = \int_{-1}^1 f(t) \cos n\pi t dt \\ a_n &= \int_{-1}^0 2(1+t) \cos n\pi t dt \\ &= 2 \left\{ \left[(1+t) \frac{\sin n\pi t}{n\pi} \right]_{-1}^0 - \frac{1}{n\pi} \int_{-1}^0 \sin n\pi t dt \right\} \\ &= 2 \left\{ (0-0) - \frac{1}{n\pi} \left[-\frac{\cos n\pi t}{n\pi} \right]_{-1}^0 \right\} = \frac{2}{n^2\pi^2} (1 - \cos n\pi) \\ &= \frac{2}{n^2\pi^2} (1 - (-1)^n) \end{aligned}$$

– sehingga;

$$a_n = 0 \quad (n \text{ even}), \quad a_n = \frac{4}{n^2\pi^2} \quad (n \text{ odd})$$

– Berikutnya adalah b_n

$$\begin{aligned} b_n &= \int_{-1}^0 2(1+t) \sin n\pi t \, dt \\ &= 2 \left\{ \left[(1+t) \frac{-\cos n\pi t}{n\pi} \right]_{-1}^0 + \frac{1}{n\pi} \int_{-1}^0 \cos n\pi t \, dt \right\} \\ &= 2 \left\{ -\frac{1}{n\pi} + \left[\frac{\sin n\pi t}{n\pi} \right]_{-1}^0 \right\} = -\frac{2}{n\pi} + \frac{2}{n^2\pi^2} (\sin n\pi) = -\frac{2}{n\pi} \end{aligned}$$

– Maka diperoleh deret fourier dari fungsi adalah:

$$\begin{aligned} f(t) &= \frac{1}{2} + \frac{4}{\pi^2} \left\{ \cos \pi t + \frac{1}{9} \cos 3\pi t + \frac{1}{25} \cos 5\pi t + \dots \right\} \\ &\quad - \frac{2}{\pi} \left\{ \sin \pi t + \frac{1}{2} \sin 2\pi t + \frac{1}{3} \sin 3\pi t + \frac{1}{4} \sin 4\pi t + \dots \right\} \end{aligned}$$

Latihan

- Tentukanlah deret fourier dari fungsi periodik berikut:

$$f(t) = \begin{cases} 0 & -2 < t < 0 \\ t & 0 < t < 2 \end{cases}$$
$$f(t + 4) = f(t).$$

Fungsi genap dan fungsi ganjil

- Fungsi Genap (even)

- Suatu fungsi $f(x)$ dikatakan genap jika $f(-x) = f(x)$

- Contoh

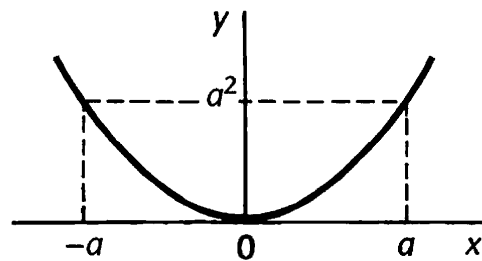

$y = f(x) = x^2$ is an even function because

$$f(-2) = 4 = f(2)$$

$$f(-3) = 9 = f(3) \text{ etc.}$$

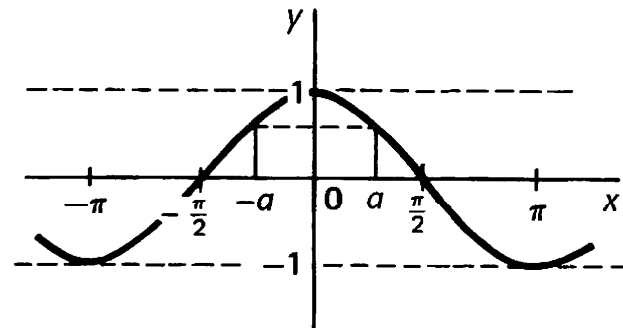

$y = f(x) = \cos x$ is an even function because

$$\cos(-x) = \cos x$$

$$f(-a) = \cos a = f(a).$$

- Grafik fungsi genap simetris terhadap sumbu y

- Fungsi ganjil (odd)

- Suatu fungsi dikatakan ganjil apabila $f(-x) = -f(x)$

- Contoh

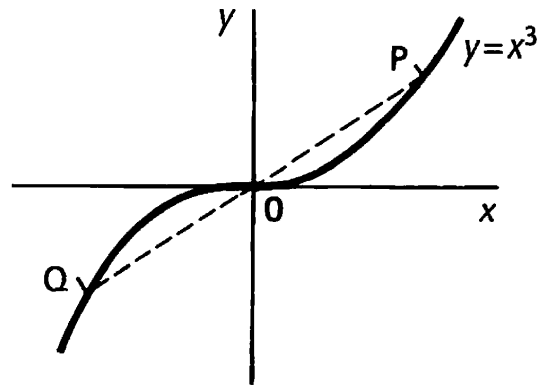

$y = f(x) = x^3$ is an odd function because

$$f(-2) = -8 = -f(2)$$

$$f(-5) = -125 = -f(5) \text{ etc.}$$

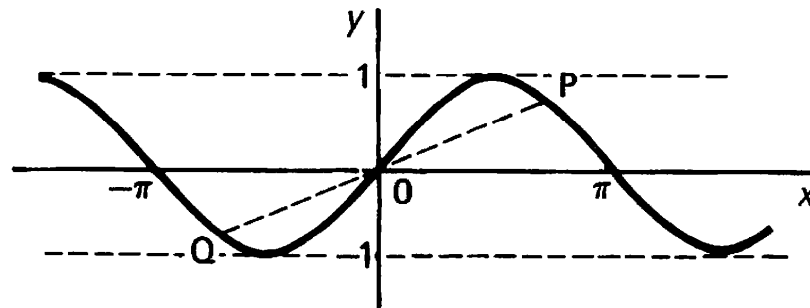

$y = f(x) = \sin x$ is an odd function because

$$\sin(-x) = -\sin x$$

$$f(-a) = -f(a).$$

- Grafik fungsi ganjil simetris terhadap titik asal (origin)

- Contoh

- Tentukanlah, apakah fungsi berikut ini genap atau ganji?

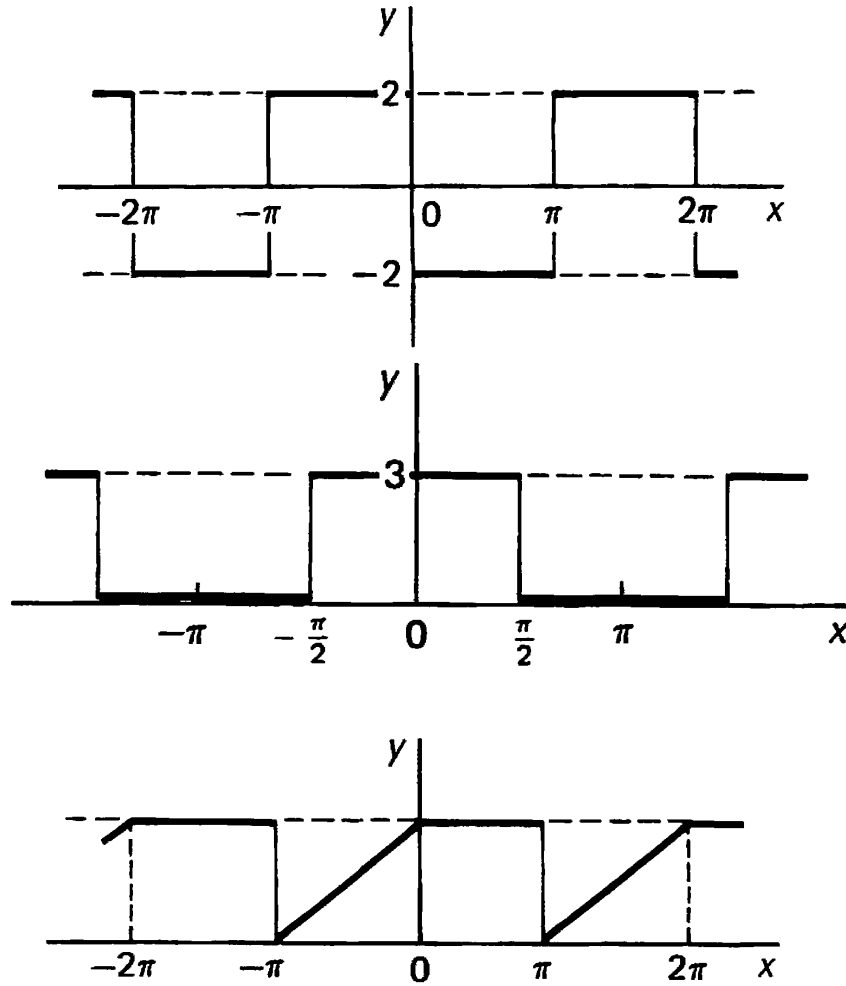

Hasi Kali Fungsi Genap dan Fungsi Ganjil

The rules closely resemble the elementary rules of signs.

$$(\text{even}) \times (\text{even}) = (\text{even}) \quad \text{like} \quad (+) \times (+) = (+)$$

$$(\text{odd}) \times (\text{odd}) = (\text{even}) \quad (-) \times (-) = (+)$$

$$(\text{odd}) \times (\text{even}) = (\text{odd}) \quad (-) \times (+) = (-).$$

Dua hal penting tentang fungsi genap dan fungsi ganjil;

(a)

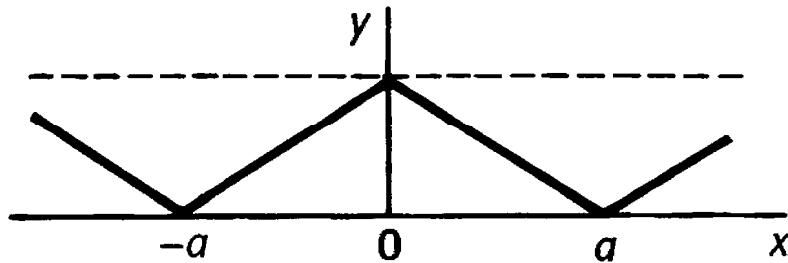

For an *even* function

$$\int_{-a}^a f(x) dx = 2 \int_0^a f(x) dx$$

(b)

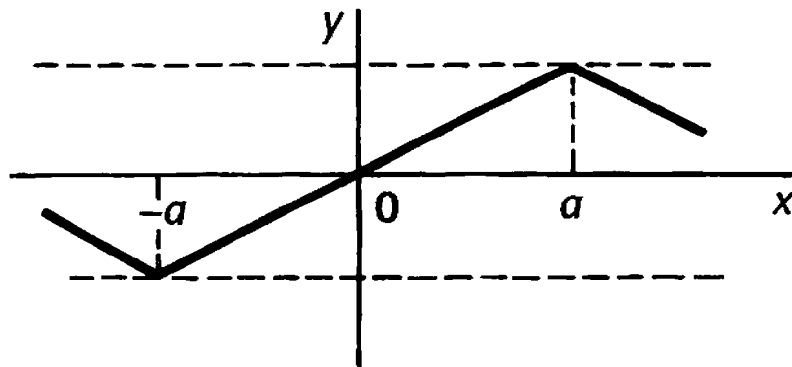

For an *odd* function

$$\int_{-a}^a f(x) dx = 0$$

- Teorema I

- Jika suatu fungsi adalah genap, maka deret fourier fungsi tersebut adalah:

$$\therefore f(x) = \frac{1}{2}a_0 + \sum_{n=1}^{\infty} a_n \cos nx$$

$$a_0 = \frac{1}{\pi} \int_{-\pi}^{\pi} f(x) dx = \frac{2}{\pi} \int_0^{\pi} f(x) dx \quad \therefore a_0 = \frac{2}{\pi} \int_0^{\pi} f(x) dx$$

$$a_n = \frac{1}{\pi} \int_{-\pi}^{\pi} f(x) \cos nx dx = \frac{2}{\pi} \int_0^{\pi} f(x) \cos nx dx.$$

- Sedangkan suku sinus bernilai nol; genap x ganjil = ganjil.

$$b_n = \frac{1}{\pi} \int_{-\pi}^{\pi} f(x) \sin nx dx = 0. \quad \therefore b_n = 0$$

- Contoh

- Tentukanlah deret fourier dari fungsi berikut:

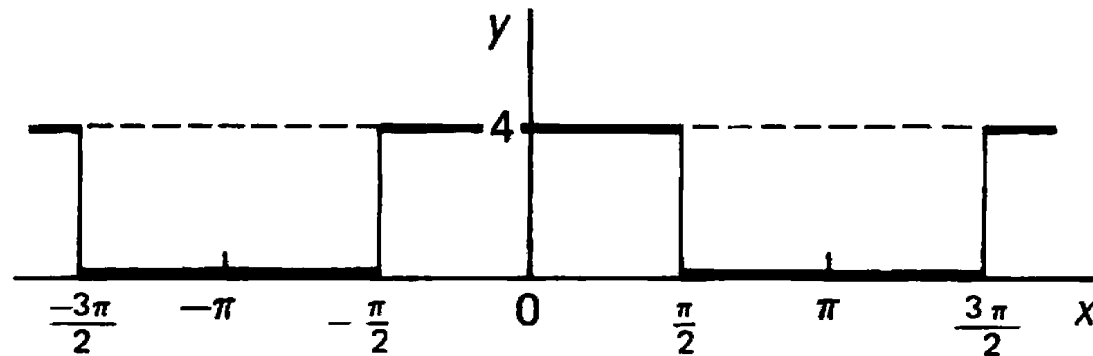

- Penyelesaian

- Karena grafik diatas adalah grafik fungsi genap, maka deret fouriernya adalah

$$\therefore f(x) = \frac{1}{2}a_0 + \sum_{n=1}^{\infty} a_n \cos nx$$

$$a_0 = \frac{1}{\pi} \int_{-\pi}^{\pi} f(x) dx = \frac{2}{\pi} \int_0^{\pi} f(x) dx = \frac{2}{\pi} \int_0^{\pi/2} 4 dx = \frac{2}{\pi} \left[4x \right]_0^{\pi/2} = 4$$

$$a_n = \frac{1}{\pi} \int_{-\pi}^{\pi} f(x) \cos nx dx = \frac{2}{\pi} \int_0^{\pi} f(x) \cos nx dx$$

$$\begin{aligned}
 a_n &= \frac{2}{\pi} \int_0^\pi f(x) \cos nx \, dx = \frac{2}{\pi} \int_0^{\pi/2} 4 \cos nx \, dx \\
 &= \frac{8}{\pi} \left[\frac{\sin nx}{n} \right]_0^{\pi/2} = \frac{8}{\pi n} \sin \frac{n\pi}{2}
 \end{aligned}$$

But $\sin \frac{n\pi}{2} = 0$ for n even

$= 1$ for $n = 1, 5, 9, \dots$

$= -1$ for $n = 3, 7, 11, \dots$ Hence the result stated.

$$f(x) = 2 + \frac{8}{\pi} \left\{ \cos x - \frac{1}{3} \cos 3x + \frac{1}{5} \cos 5x - \frac{1}{7} \cos 7x + \dots \right\}$$

- Teorema II

- Jika suatu fungsi adalah ganjil, maka deret fourier fungsi tersebut hanya mengandung komponen sinus.

$$f(x) = \sum_{n=1}^{\infty} b_n \sin nx$$

$$b_n = \frac{2}{\pi} \int_0^{\pi} f(x) \sin nx \, dx$$

- Suku awal dan suku cosinus bernilai nol;

$$a_0 = \frac{1}{\pi} \int_{-\pi}^{\pi} f(x) \, dx. \quad \text{But } f(x) \text{ is odd} \quad \therefore a_0 = 0$$

$$a_n = \frac{1}{\pi} \int_{-\pi}^{\pi} f(x) \cos nx \, dx$$

$$a_n = \frac{1}{\pi} \int_{-\pi}^{\pi} f(x) \cos nx \, dx = \frac{1}{\pi} \int_{-\pi}^{\pi} (\text{odd function}) \, dx = 0$$

$$a_n = 0 \quad (\text{including } a_0 = 0)$$

- Contoh

- Tentukanlah deret fourier dari fungsi berikut:

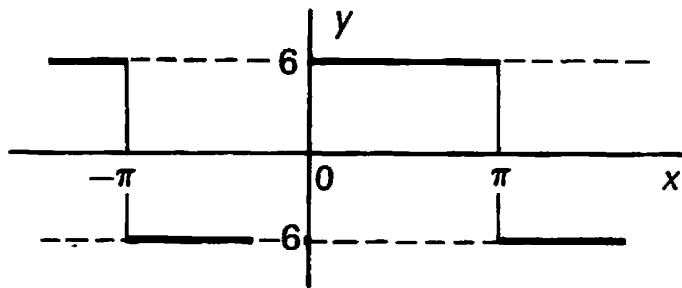

$$f(x) = -6 \quad -\pi < x < 0$$

$$f(x) = 6 \quad 0 < x < \pi$$

$$f(x + 2\pi) = f(x).$$

- Penyelesaian

- Karena grafik diatas adalah grafik fungsi ganjil, maka deret fouriernya

adalah
$$f(x) = \sum_{n=1}^{\infty} b_n \sin nx$$

$$b_n = \frac{2}{\pi} \int_0^{\pi} 6 \sin nx \, dx = \frac{12}{\pi} \left[\frac{-\cos nx}{n} \right]_0^{\pi} = \frac{12}{\pi n} (1 - \cos n\pi).$$

$$f(x) = \frac{24}{\pi} \left\{ \sin x + \frac{1}{3} \sin 3x + \frac{1}{5} \sin 5x + \dots \right\}$$

Quiz....

- Tentukan deret fourier dari grafik berikut:

